



The MBA series Alarm Bells are low-current, audible signaling devices for use in Fire Alarm Systems and other signaling applications to provide warning during emergencies.

The Bells are polarized for usage with supervision circuitry, with low current, high efficiency DC motor to drive the striker. The Bell Gong is made of steel, finished in red enamel paint with the mechanism enclosed in an ABS plastic housing.

Back Box BBX-4 (To be ordered separately), could be used in conjunction with the Bell as an option for outdoor installation, or when weatherproof installation is required.

DESCRIPTION	ALARM BELL MBA-624	BACK BOX BBX-4 Optional (To be ordered separately)
Weight	680g	300g
Material	Gong : Steel (Red) Housing : ABS Plastic	Light Alloy (Painted Red)
Rated Voltage	24 VDC	-
Rated Current	≤ 20 mA	-
Voltage Range	19.2 to 28.8 VDC	-
Sound Level	95 dB at 3m (10 ft.)	-

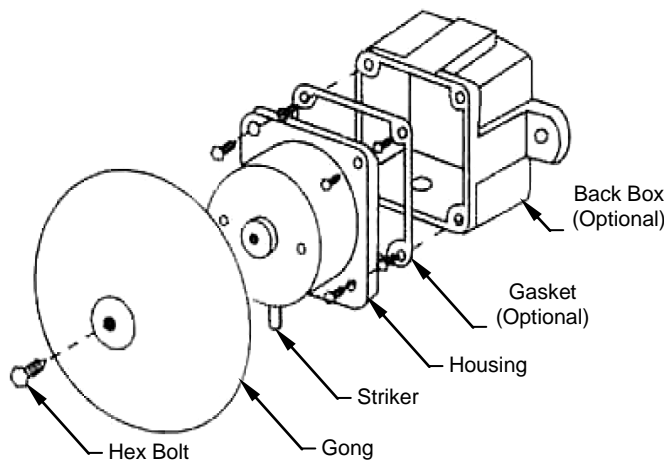

Typical Bell Installation with optional Back Box



Alarm Bell MBA-624 Dimension



**Back Box BBX-4
For Outdoor Installation
(To be ordered separately)**

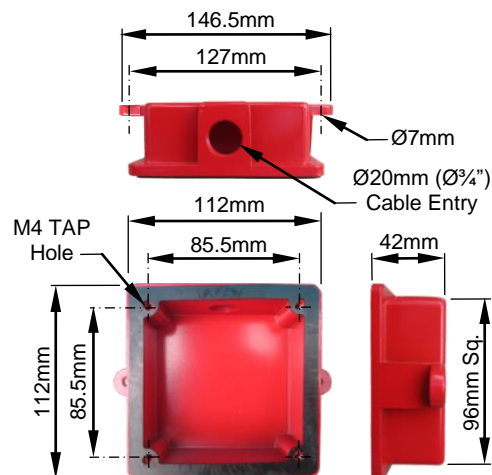

Back Box BBX-4 Dimension

Multron Systems Pte Ltd

217 Kallang Bahru, Multron Building, Singapore 339 347

6395 6868
6395 6869

info@multron.com
www.multron.com

